



# 8600



### Specifications

<b>Overall</b>		
Length	48' 6" travel	61' 0" operation
Height	13' 2" travel	17' 10" operation
Width	10' 8"	
Weight	92,000 pounds	
<b>Feed Conveyor (high troughing)</b>		
Length	16'	
Width	60"	
<b>Rotor (forged)</b>		
Length	60"	
Diameter	50"	
Wall thickness	4"	
Weight	12,500 pounds	
Hammers	24	
Hammer weight	66 pounds, each	
Tips, reversible	7 pounds, each	
<b>Discharge Conveyor</b>		
Length	50' 0"	
Width	60"	
Discharge height	17' 10"	
<b>Throughput</b>		
Power	up to 200 tons/hour	
<b>Drive</b>	CAT 3412E, 1030 HP (effective 2006, CAT C32 rated at 1300 HP)	
<b>Fuel Tank</b>	V-belt complete; 12-groove, 8-V, with guard	
	382 gallons	

**Electrical** Radio remote control for all functions, with full, independent mechanical backup; 3 E-stops placed around machine; CAT engine RPM sensor regulates feed system

**Options**  
**Flexaire Fan** Blades reverse pitch every five minutes, reversing airflow automatically to keep radiator cool and clean, eliminating costly shutdown

**Magnetic Head Pulley** With aluminum diverter chute

**Overband Magnet** With metal chute and bolt-on quick disconnect hydraulics. Magnet can remain on during transport.

### Features

- Unique clamshell hogbox design provides full access for maintenance and direct lifting line for screen removal
- Three easy slide-in screens
- Extra-thick, shear pin protected, screen, support frame, and anvil
- 50"x60" downturn rotor made of 4" thick high-strength forged steel
- Built-in prescreener allows bypass of abrasive fines
- CBI's Replace-A-Face™ hammer system
- IntelliGrind™ variable speed feed system
- Throughput up to 200 tons/hour

### Description

If your need is for the highest possible production grinding trees, stumps brush, yard waste or pallets, then the 8600 is for you. Following in the tradition of CBI's 4800 series, the Magnum Force 8600 incorporates the extreme ruggedness and versatility of that model and adds newly engineered features never before available in a wood waste grinder. The 8600's unique clamshell design provides outstanding access for service, and a direct line for lifting and removing screens. Screens are specially designed to slide in easily, and the three screen system allows for product size to can be readily customized to meet end-product requirements. Other features, such as CBI's IntelliGrind™ operating system and Replace-A-Face™ hammers, make this unit the most technically advanced on the market today. As with all CBI products, every feature and component is designed for the longest wear life, easiest maintenance, and lowest cost of operation possible.

#### Hog Chamber, Rotor, and Anvil

The hog chamber is a heavy-duty reinforced housing with 100% continuous welds, providing maximum corrosion resistance, and the ultimate in rigidity and strength. Bolt-in, Hardox 400 wear liners simplify maintenance.

A 50" diameter, 4" thick high strength forged steel rotor, with bolt-on hammers and tips, is designed especially for yard waste, stumps and logs. The rotor has 24 machine pockets to accept CBI's patented 5 bolt hammer & tip combination, and rotates downward at 900 RPM. Each hammer is bolted to the rotor core and the reversible tip is bolted to the hammer; an extremely rugged construction design for long life and easy maintenance. Both hammer and tip are engineered with a unique breakaway feature for full and effective protection against tramp metal. In case of release, one man can

quickly replace defective parts and be up and running with little time lost. CBI's new Replace-A-Face™ hammer system allows for quick, easy, and inexpensive repairs, as the face can be replaced independent of the rest of the hammer. The superior clampload of hammer and tip design prevent items from becoming loose and eliminates the need for re-tightening. The oversized, line-bored, heavy duty bearing housing is designed to absorb the shock and heavy stresses of grinding contaminated materials.

Extra thick, shear-pin protected, screens, grates, and anvil provide longer wear with less breakage, avoids catastrophic damage, and can be replaced easily. A built-in prescreener allows abrasive fines to bypass the hog and extends component wear life.

The hog box has a unique clamshell design providing full access for maintenance and a direct line to lift and remove screens. The push of a single button retracts the two main lock pins, and a second button activates two hydraulic cylinders that lift the entire upper section to just over center-vertical position. A three-screen system, newly designed for easy slide-in and removal, allows for product size that can be easily customized depending on feedstock and end product requirements. Several sizes and patterns are available ranging from 1"x2" regrind grates, up to 6"x9" for high production on primary grind. Anvil and grates are supported by heavy duty shear pins for rotor protection.

#### Frame

The trailer frame features a wide flange and tubular lattice structure for high rigidity and strength while greatly reducing weight. The tri-axle features a Hutchens H9700-50 suspension and a 9' - 6" tire spread. Six super-single wheels with Michelin 425-65R22.5 tires

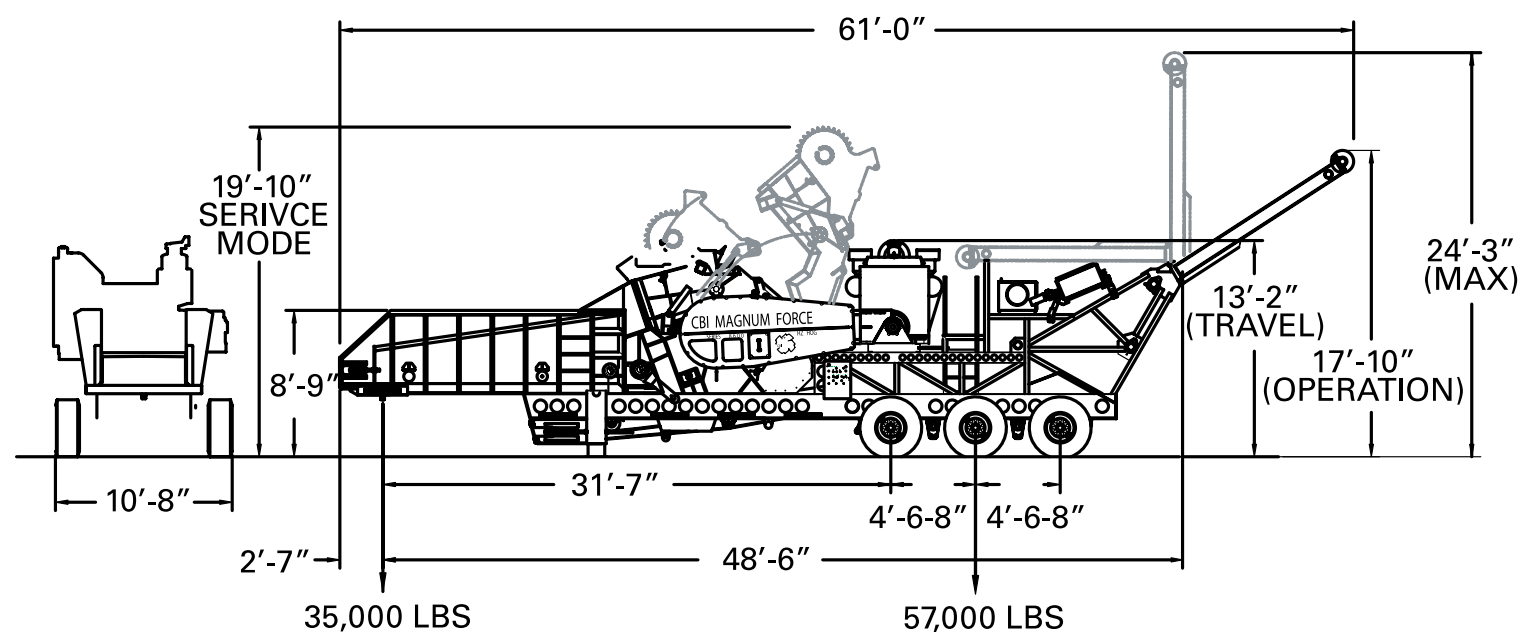

The CBI difference: More Value — by Design

**Continental Biomass Industries, Inc.**

World's Best Stationary and Portable Material Recovery Systems

22 Whittier Street, Newton, NH 03858  
 Phone: 603-382-0556 Fax: 603-382-0557  
 Web: cbi-inc.com Email: info@cbi-inc.com

Distributed by:

# Outstanding Throughput... Extreme Duty... More Value... by Design

provide a smooth, reliable ride, and good flotation on the job site; and, because debris can't be trapped – as often happens in the space between dual tires -- there's significantly less chance of blowouts. Two front stabilizers with 5" cylinders provide the necessary stabilization and leveling flexibility for any site.

## Feed System

The 16' long x 60" wide feed conveyor has a fluted (funneling) high troughing design, facilitating continuous feed to the hog chamber. The open-ended design and extra large capacity simplifies feeding full-length materials and accommodates large material surges. A dual, upper and lower, feed roll system powered by three heavy-duty, high-torque planetary and direct hydraulic drives, provides continuous, positive feed even for large or bulky materials such as whole trees, logs, telephone poles, stumps, or railroad ties. The upper roller, with internal drive, has a crush force that is adjustable by radio control. The entire feed system is load regulated.

## Discharge Conveyor

The single catenary discharge conveyor is 60" wide, and features a 330, 3-ply cleated, heavy-duty belt. It is driven by a direct-coupled hydraulic drive. There is no opportunity for material to bridge under the rotor, and with no transition point, spillage and cleanup are eliminated. With the optional crossbelt magnet, the extra width allows for effective removal of metal and maximum performance. The upper section of the conveyor is hydraulically folded for travel.

## Power Unit

The unit is powered by a Caterpillar 3412E diesel, rated at 1050 HP (effective in 2006, this will be replaced by the CAT C32 rated at 1300 HP). Two clutch options are available – a Twin Disc® Model 318 extra heavy-duty PTO clutch with outboard support bearing, PT Tech hydraulic actuator, and independent controller that pulses at designed intervals to bring the rotor up to speed, eliminating the need to manually engage and adjust the mechanism, is standard. Also available is the Twin Disc HP600 hydraulic wet clutch. Access to the engine from both sides simplifies maintenance. Additional features include an extra long rubber grommetted Copper Core radiator for dusty operation, Donaldson Air Filtering System with Turbo Two Pre-Cleaners, 8" Silencer, dual battery, 24 volt DC electrical system, emergency shutdown, all-weather control enclosures, and a Flexaire reversible fan that reverses airflow every 15 minutes keeping the radiator clean of dirt and debris.

## Hydraulics/Paint/Misc.

Pressure and flow compensated hydraulic pumps are used, which generate less heat and less component stress, while prolonging equipment life. Single function fusing and wiring, with terminal blocks, is well-routed in harnessed cables, extending component life, simplifying maintenance, and providing a better overall appearance. Each subassembly is sandblasted, epoxy primed, and painted completely before final assembly using CBI's extended life painting process, resulting in enhanced corrosion resistance, better appearance and resale value.

8600

IntelliGrind™ incorporates feed speed that varies automatically with engine load, and an optional modem communications system that provides for real-time system diagnostics, analysis, and operating program adjustments allowing the operator to optimize performance while avoiding costly downtime.



Hog box opens in seconds with the push of a button giving full access to rotor and quick-change screens... No more bending, sore backs, or scraped knees.

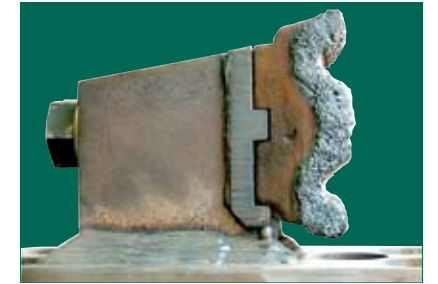

Quick, easy, inexpensive repairs with CBI's Replace-A-Face™ hammer system.

Wide discharge conveyor for high volume throughput; folds for transport.

Dual upper-lower feed roller system powered by two heavy duty planetary and high torque motors.

Twin Disc 318 clutch with PT Tech Hydraulic Actuator or Twin Disc HP600 hydraulic clutch.

Large capacity feed hopper easily handles full-length trees or large material surges with no problem.

Super single wheels feature Michelin tires, provide high on-site flotation and no trapped debris or blowouts.



Heavy-duty shear pins protect screens and anvil.

## In the Field



Stumps and Logs



Regrind of Mulch (shows optional overband magnet)



Yard Waste



"Unbelievable.....These CBI 8600's are "flippin'" unbelievable. They primary grind Australian pine, yard waste, and they make a beautiful mulch at a rate so high we had to buy a loader with a 27 yard bucket just to keep up. We love them... Thanks CBI."

Chuck Tomlinson  
Amerigrow Recycling  
Delray FL